



1120 North Main Street • Elkhart, IN 46514
 PHONE: 574•264•2131 FAX: 574•206•9713
 INTERNET: http://www.atwoodmobile.com

LITERATURE NUMBER MPD 75026

GOOSENECK COUPLERS

ENGLISH, FRANÇAIS (et Canada)

•Installation •Operation •Maintenance

Effective 11/21/07

SAFETY ALERT SYMBOLS

Safety Symbols alerting you to potential personal safety hazards. Obey all safety messages following these symbols.

WARNING
 avoid possible injury or death

CAUTION
 avoid possible injury and/or property damage

FOR YOUR SAFETY READ ALL INSTRUCTIONS BEFORE INSTALLATION AND OPERATION

Installer: Provide these instructions to the consumer.
Consumer: Keep documents for future reference.

The Atwood Gooseneck Coupler or Gooseneck Coupler and Stem is a ball type coupler designed to be used on trailers that are towed by vehicles having the ball mounted above and forward of the rear axle.

Identify Gooseneck Coupler and follow correct installation and maintenance instructions for that part number.

INSTALLATION

CAUTION
HAZARDOUS FUMES

- adequate ventilation must be provided when welding.

WELDING INSTRUCTIONS

- M.I.G. OR STICK** - Make 5/16" fillet welds minimum. Use No. E6011 AWS welding rod, 5/16" diameter. Machine amps (AC or DCRP) 2 160-180 amps with 50 volts.
- M.I.G. WELDING** - Use A.W.S. ER 70S-3 or 6 wire or equivalent with a diameter of .035 - .045. The recommended shielding gas mixture is 75% - 95% Argon & 25% - 5% CO₂.
- STICK WELDING** - Use E6011 A.W.S. welding rod or equivalent with a diameter are as follows: 1/8" electrode set power between 115-130 Amps DC or 5/32" electrode set power between 140-160 Amps DC.

MPD 75025 GOOSENECK COUPLER 25,000 LB. CAP.

Max. Gross Vehicle Weight: 25,000 lbs.
Ball Size: 2-5/16" diameter
Vertical Load Capacity: 5,000 lbs.

This gooseneck coupler must be installed **ONLY** by welding to the gooseneck tube of gooseneck type trailers.

- Center ball cup 1-A inside the end of gooseneck tube 1-B. Line up the guide 1-C ramp toward forward end of trailer.
- Attach coupler to gooseneck tube by welding all around where tube base meets coupler. Use 5/16" fillet weld No. E6011 AWS welding rod 5/16" diameter. Machine amps (AC or DCRP) @ 160-180 with 50 volts.
- See **Coupling and Uncoupling Procedures and Maintenance**.

GOOSENECK COUPLER WITH STEM

DROP TUBE STEM WITH COUPLER MPD 75401
SCREW ADJUSTABLE STEM WITH COUPLER MPD 75004
Max. Gross Vehicle Weight: 25,000 lbs.
Ball Size: 2-5/16" diameter
Vertical Load Capacity: 5,000 lbs.

DROP TUBE AND SCREW ADJUSTABLE STEM APPLICATIONS -

- Weld the outer tube to the trailer frame and gusset the tube with side plates of sufficient capacity for the trailer GVRW and design.
- Weld the top and bottom of the side plates. Weld both sides of the plates 4-A.
- Weld the top and bottom areas where the trailer frame meets the gooseneck stem. 4-B
- Weld the entire length of the side plates where they meet the trailer frame. Weld both sides. 4-C
- Dimensional limits for gooseneck attachment:
 3-C 3/8" thick side plates 3-D 3/4" 3-E 24-3/16"
 3-F 8" minimum 3-H 3-1/2" maximum
 3-G 2-1/16" minimum to 12-1/16" maximum
- Check all welds for correct size, penetration and location.

OPERATION

WARNING

PERSONAL INJURY / PRODUCT DAMAGE

- Safe towing practice requires the proper use of safety chains used in accordance with instructions provided by the trailer manufacturer.
- Use only a 2-5/16" diameter hitch ball with the correct towing weight capacity.
- Check that the ball has been completely inserted into the coupler ball socket and the ball clamp (inside the coupler) is closed around the underside of the tow ball and the latch is in the closed position.
- The loaded weight of the trailer must never exceed the minimum capacity marked on the coupler, tow ball, hitch, trailer or vehicle.
- Check coupler, hitch and ball for damage or wear before each use. Assure all parts operate freely. Replace any component if worn or damaged.
- Failure to follow warnings and instructions could result in separation of tow vehicle and trailer which can result in death, personal injury and property damage.
- Use caution when backing or towing vehicle for hook-up, damage to coupler may result.

DROP-TUBE STEM & COUPLER

MPD 75401

- Put the drop-tube stem in the proper position before connecting it to the hitch ball in the pick-up bed. This will allow level towing of the trailer. Adjustments can be every 2", up to 10" maximum 4-D.
- Adjust the stem so your truck/trailer combination is in a correct level towing position. When adjusting the stem all weight must be off the gooseneck stem and coupler. Use the trailer jacks to raise the coupler off the hitch ball above the truck bed before removing the 1" diameter bolt from the stem. Raise or lower the stem as needed. Replace the bolt and nut. Tighten to 100 ft./lbs. torque.
- See **Coupling and Uncoupling Procedures and Maintenance**.

SCREW ADJUSTABLE STEM & COUPLER

MPD 75004

- The adjustable screw stem is adjustable over a 10" length 3-G. This stem can level the trailer before or after hook-up is made to the hitch ball in the pick-up bed.
- To raise the trailer, lift the adjustable stem handle 3-B and turn it counterclockwise ↺.
- To lower the trailer, lift the adjustable stem handle 3-B and turn it clockwise ↻.
- See **Coupling and Uncoupling Procedures and Maintenance**.

COUPLING PROCEDURE

MPD 75401 & 75004

1. On level ground place wheel chocks in front and behind wheels, both sides of the trailer (4 chocks).
2. FIG 1 shows coupler handle in a latched position. To open, rotate handle FIG 2-D counterclockwise a sufficient amount to allow handle tab FIG 1-E to clear rivet tab FIG 1-F, then pull handle away from coupler and position handle tab under rivet on outside of rivet tab as in FIG 2.
3. Adjust trailer jacks until coupler is at level height or slightly lower (by 1") than top of hitch ball.
4. Lower tailgate of truck.
5. Back truck slowly toward trailer until coupler drops into place over the ball. Check to see that the ball has entered the ball cup of the gooseneck coupler.
6. Coupler will not completely lock into place until trailer jacks are retracted.
7. Connect power line, breakaway switch line and safety chains between truck and trailer (see trailer manufacturer's instructions).
8. Retract trailer jacks.
9. Check to make sure that the handle is in latched position. Place lock pin FIG 2-G in holes of tabs FIG 2-H, pinning the handle in place.
10. Close and latch tailgate. Check all lights - stop, turn, tail, and brake lights for proper operation.
11. As an additional check before towing, extend jacks until truck is raised 3 to 4" to verify that coupler is securely attached to ball.
12. Completely retract trailer jacks.
13. Pick up and store wheel chocks.

UNCOUPLING PROCEDURE

MPD 75401 & 75004

1. On level ground place wheel chocks in front and behind wheels, both sides of the trailer (4 chocks).
2. Lower trailer jacks. If on soft ground, place a support under the jack feet to prevent trailer from settling.
3. Lower tailgate on truck.
4. Remove the lock pin FIG 2-G and rotate handle counterclockwise. Pull handle FIG 2-D away from coupler and position the handle tab FIG 2-E under rivet on rivet tabs FIG 2-I.
5. Raise trailer until jacks lift coupler completely above the top of ball.
6. Disconnect power line, breakaway switch line and safety chains between truck and trailer.
7. Drive truck slowly away from under trailer.

MAINTENANCE



WARNING

PERSONAL INJURY / PROPERTY DAMAGE

- Replace worn or damaged parts.
- Do not tow trailer with worn or damaged parts.

GOOSENECK COUPLER

MPD 75025

1. Monthly, clean ball cup and clamp, lubricate with wheel bearing grease.
2. Monthly, apply SAE 30 oil at points where the handle rotates at sides of coupler.
3. Check ball and coupler before each trip for wear.

DROP-TUBE STEM & COUPLER

MPD 75401

1. Before each use check torque on the 1" diameter bolt 4-E, it should be 100 ft/lbs.

SCREW ADJUSTABLE STEM & COUPLER

MPD 75004

1. On level ground place wheel chocks in front and behind wheels, both sides of the trailer (4 chocks). Disconnect the coupler from the hitch ball.
2. To lubricate the adjustable stem, extend the coupler as far as possible, and squirt SAE 30 oil into the top of the stem where the screw extends out of the top.
3. After oiling, completely retract the stem, and reposition it as described in Operation Instructions.

For problems or questions, contact your dealer, the trailer mfg., or Atwood's Consumer Service Department 574-264-2131.

Atwood Hardware Systems & Components Limited Warranty

For warranty information contact Atwood (574-264-2131) before having any work done. Atwood Mobile Products warrants to the original purchaser that this product will be free of defects in material and workmanship for a period of 2 years from the date of purchase. Atwood's liability hereunder is limited to the replacement of the product, repair of the product, or replacement of the product with a reconditioned product at the discretion of the manufacturer. The warranty is void if the product has been damaged by accident, unreasonable use, neglect, tampering or other causes not arising from defects in material workmanship. The warranty extends to the original consumer purchaser of the product only, and is subject to the following conditions:

1. For two (2) years from the original date of purchase, Atwood will replace or repair or replace with conditioned product, at Atwood's discretion, product found to be defective in material or workmanship. Weights on each individual leg are required to process the warranty request.
2. In the event of a warranty claim, the Original Owner must contact the Atwood Consumer Service Department, 1120 North Main St., Elkhart, IN 46514, Telephone: 574-264-2131 Fax: 574-206-9713. Warranty claim service must be performed as approved by the Atwood Consumer Service Department. Warranty replacement hardware systems and com-

ponents or parts will be furnished freight prepaid. Labor cost to repair or replace will be limited to the amount of the original purchase price of the systems and components. The replaced warranty products or parts become the property of Atwood Mobile Products and must be returned to the Atwood Consumer Service Department freight prepaid, unless prior arrangements have been agreed to.

3. This limited warranty is valid only when the product is applied, installed, maintained and operated in accordance with this Atwood Installation, Maintenance and Operating Manual. Any deviation from these recommended specifications must be approved in writing by Atwood.
4. Any implied warranties are limited to the duration of this limited warranty as stated above. Atwood does not assume responsibility for consequential damage or loss, including loss of use of vehicle, loss of time, inconvenience, expense for gasoline, telephone, travel, lodging, loss or damage to personal properties, or loss of revenues. Some states do not allow limitations on how long an implied warranty lasts or limitations on consequential damages, so the above limitations may not apply to you. This limited warranty gives you specific legal rights which may vary from state to state.

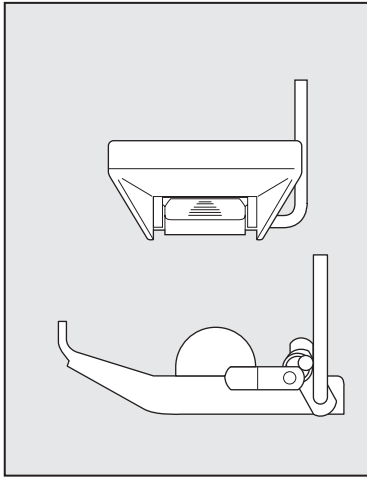

75025

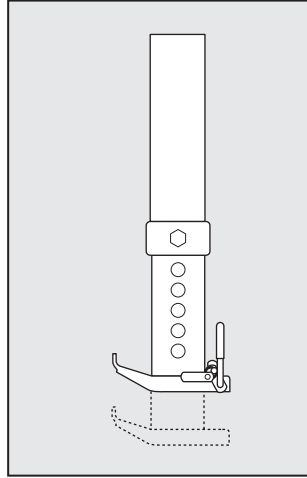

75401

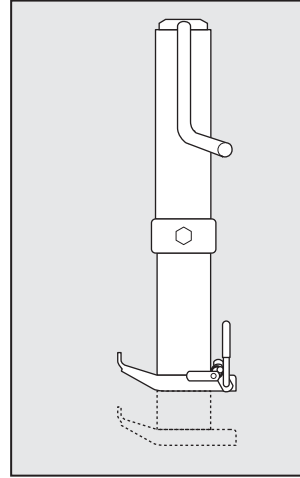

75004

