



1120 North Main Street • Elkhart, IN 46514
PHONE: 574•264•2131 **FAX:** 574•206•9713
INTERNET: http://www.atwoodmobile.com

LITERATURE NUMBER MPD 87985

THUMB LATCH COUPLERS

ENGLISH, FRANÇAIS (et Canada)

•Installation •Operation •Maintenance

Effective 11/21/07

SAFETY ALERT SYMBOLS

Safety Symbols alerting you to potential personal safety hazards. Obey all safety messages following these symbols.

⚠ WARNING
avoid possible injury or death

⚠ CAUTION
avoid possible injury and/or property damage

FOR YOUR SAFETY READ ALL INSTRUCTIONS BEFORE INSTALLATION AND OPERATION

Installer: Provide these instructions to the consumer.
Consumer: Read and keep documents available for future reference.

REFERENCE FIGURES FOUND ON PAGE 3

INSTALLATION

⚠ CAUTION HAZARDOUS FUMES

- Adequate ventilation must be provided when welding.
- Coupler latching mechanism must operate freely after welding installation.
- Do not clamp ground strap to latch during welding.

PRODUCT DAMAGE

WELDING INSTRUCTIONS

- **M.I.G. OR STICK**-Attach couplers with 5/32" fillet weld minimum.
- **M.I.G. WELDING**-Use A.W.S. ER 70S-3 or 6 wire or equivalent with a diameter of .035 - .045. The recommended shielding gas mixture is 75% - 95% Argon & 25% - 5% CO₂.
- **STICK WELDING** - Use E6011 A.W.S. welding rod or equivalent. Recommended machine settings for specific electrode diameter are as follows: 1/8" electrode set power between 115-130 Amps DC or 5/32" electrode set power between 140-160 Amps DC.

UNDERSLUNG COUPLER

PART # 82680, 82681, 82682 **13,000 lb. Capacity**

- Top Plate PART # 82740 or 22375**
- On I-beams remove approximately 9" of outside bottom flange of the I-beams (FIG 5-A) so coupler can be welded directly to the I-beam web. For an alternative to removing a length of the I-beam flange:
 - Make two plates 9" long x .135" thick x height of I-beam (FIG 2-B & 5-E).
 - Weld the plates to the outside of the I-beam flanges.
 - Weld both plates full length top and bottom following **WELDING INSTRUCTIONS**.
 - With bottom of beam contacting inside bottom coupler, butt front edge of beams against back of ball housing. Edges of beams must make full contact with inside surface of coupler sides.
 - On beams with flanges wider than 1-15/16", trim front corners (FIG 2-C) to allow beams to penetrate fully into coupler.
 - Following **WELDING INSTRUCTIONS**, weld full length, both sides of coupler, with a continuous weld (FIG 5-B). Weld must run from rear edge of coupler past front edge of beam, then onto inside of coupler (FIG 5-D). Weld bottom rear edge of coupler to bottom of trailer frame.

⚠ CAUTION COUPLER OR FRAME DAMAGE

- Top support plates must be used with all underslung couplers.
- Align hole in top plate with hole in coupler (FIG 5-F). Following **WELDING INSTRUCTION** to assure structural integrity of coupler attachment system, weld top support plate to frame full length both sides and around the corner to inside edges of the trailer frame (FIG 5-C).

TOP MOUNT A-FRAME COUPLERS

⚠ CAUTION COUPLER OR FRAME DAMAGE

- A bottom support plate **MUST** be used with A-Frame couplers.
- Weld completely around bottom plate following **WELDING INSTRUCTIONS**.

BOX BEAM APPLICATION

Part # 81916 (Kit includes 81917 bottom plate) **15,000 lb. Capacity**
Part # 81912 **13,000 lb. Capacity**
SAE/CSA Class 4 Part # 81911, 81915 **10,000 lb. Capacity**

- Bottom Plate PART # 81917, 82672, 83400, 83470, 83511, 84150, 84160, 86081**
- Penetration of trailer frame into coupler must be 8" minimum measured along coupler sides (FIG 1-A).
 - Following **WELDING INSTRUCTIONS** weld full length on both sides, from rear of coupler under flange and past front edge of trailer frame to inside of coupler (FIG 1-B).
 - A bottom support plate must be used to assure structural integrity of coupler attachment system. Align hole in bottom support plate with hole for jack in coupler (FIG 1-C). If there are mounting holes in the support plate, align them with the mounting holes in the coupler. Following **WELDING INSTRUCTIONS** to assure structural integrity of coupler attachment system, weld bottom support plate to frame full length both sides and around the corner to inside edges of the trailer frame.

I-BEAM APPLICATION

Part # 81916 (Kit includes 81917 bottom plate) **15,000 lb. Capacity**
Part # 81912 **13,000 lb. Capacity**
SAE/CSA Class 4 Part No. 81911, 81915 **10,000 lb. Capacity**

- Bottom Plate PART # 81917, 82672, 83400, 83470, 83511, 84150, 84160, 86081**
- For I-beams, remove approximately 9" of outside top flange of the I-beam (FIG 2-A), welding coupler directly to web of beams. For an alternative to removing a length of the I-beam flange:
 - Make two plates 9" long x .135" thick x height of I-beam (FIG 2-B).
 - Weld the plates to the outside of the I-beam flanges.
 - Weld both plates full length top and bottom following **WELDING INSTRUCTIONS**.
 - With top of beams contacting inside top of coupler, butt front edge of beams against back of welded plate on coupler. Edges of beams must make full contact with inside surface of coupler sides.
 - On beams with flanges wider than 1-15/16", trim front inside corners to allow beams to penetrate fully into coupler (FIG 2-C).
 - Penetration of frame into coupler must be 8" minimum measured along sides (FIG 1-A).
 - Following **WELDING INSTRUCTIONS**, weld full length on both sides, from rear of coupler under flange and past front edge of trailer frame to inside of coupler (FIG 1-B).
 - A bottom support plate must be used to assure structural integrity of coupler attachment system. Align hole for jack in bottom support plate with hole for jack in coupler (FIG 1-C). Follow **WELDING INSTRUCTIONS** to assure structural integrity of coupler attachment system weld bottom support plate to trailer frame full length both sides and around the corner to inside edges of the trailer frame.

STRADDLE MOUNT COUPLERS

CAUTION COUPLER OR FRAME DAMAGE

• **MPD 83462 AND MPD 83549 - 44,000 LB. MOBILE HOME COUPLERS - Use only on mobile home applications** These couplers are for one time use to tow a mobile home.

DO NOT RECYCLE/REUSE THE COUPLER - TOW BAR ASSEMBLY.

- Straddle mount couplers are to be used only on mobile homes.
- Top and bottom support plates **MUST** be used with all Straddle Mount Couplers.
- Do not mount couplers directly onto corrugated type beams
- Must use 50° coupler with a 50° A-frame only.
- Must use 60° coupler with a 60° A-frame only.
- Larger beam reinforcements and improved attachments may be necessary for adequate structural capacity.

PART # 83461, 84102 - 50° coupler	32,000 lb. Capacity
PART # 83462 - 50° coupler	44,000 lb. Capacity
PART # 83551, 83556 - 60° coupler	32,000 lb. Capacity
PART # 83549 - 60° coupler	44,000 lb. Capacity
Top Plate PART #	22375, 82740, or 83480 (50°), or 83670 (60°)
Bottom Plate	82672, 83400, 83470, 83511, 84150, 84151, 84160, 84161, 86081

1. Butt front edge of beam web against the end of slot in top of coupler and back of plate at bottom of coupler (FIG 3).
2. If necessary, remove the front inside corners (FIG 2-C) of the I-beam flange to allow beams to penetrate fully into both sides of the coupler.

CAUTION COUPLER OR FRAME DAMAGE

• Following **WELDING INSTRUCTIONS** weld around front of beam and on inside of beam.

3. Following **WELDING INSTRUCTIONS** weld along top, back and sides specifically under flange and around slots in coupler (FIG 3-A).
4. When installing coupler at top of I-beam, provide for clearance between latch and flanges of beams for proper operation. Weld coupler to front edge of I-beam flange and top of coupler sides to underside of I-beam flange (FIG 3-B).
5. Align hole in top support plate with hole in bottom support plate (FIG 3-C, 4-B). Following **WELDING INSTRUCTIONS** to assure structural integrity of coupler attachment system weld bottom support plate to trailer frame full length both sides and around the corner to inside edges of the trailer frame.

Part # 84140 - 50° coupler	40,000 lb. Capacity
Part # 84060 - 60° coupler	40,000 lb. Capacity
Top Plate PART #	83480 (50°), or 83670 (60°)
Bottom Plate PART #	82672, 83511, 84150, 84160

1. Butt front edge of beam web against the end of slot in top and bottom of coupler (FIG 4).
2. If necessary, remove the front inside corners (FIG 2-C) of the I-beam flange to allow beams to penetrate fully into both sides of the coupler.

CAUTION COUPLER OR FRAME DAMAGE

• Following **WELDING INSTRUCTIONS** weld around front of beam and on inside of beam.

3. Using **WELDING INSTRUCTIONS** weld along top, back and sides specifically under flange and around slots in coupler completely to integrate coupler and I-beams (FIG 4-A).
4. When installing coupler at top of I-beam provide for clearance between latch and flanges of beams for proper operation. Weld coupler to front edge of I-beam flange and top of coupler sides to underside of I-beam flange (FIG 4-B).
5. Align hole in top support plate with hole in bottom support plate (FIG 4-C). Following **WELDING INSTRUCTIONS** to assure structural integrity of coupler attachment system weld bottom support plate to trailer frame full length both sides and around the corner to inside edges of the trailer frame.

CAUTION COUPLER OR FRAME DAMAGE

• Weld top and bottom of coupler, both sides.

ADJUSTABLE COUPLER

WELD ON BRACKET APPLICATION

1. **POSITIONING BRACKET** - Center bracket side to side on trailer tongue with bracket height adjusted to meet your towing needs (FIG 9). Allow adequate ground clearance and provide position options for coupler. Trailer must travel in a level, horizontal to ground position. This will provide optimal coupler axle loading and range of motion. Support mounting bracket sides with C-clamps or bolts before welding to prevent distortion of brackets during welding process. Inside dimension of bracket must be 3.00"±.03" after welding (FIG 4-A).
2. Follow **WELDING INSTRUCTIONS**.
3. Weld along top, bottom and sides of bracket where it meets trailer tongue. Add gussets (5/16" thick steel plate) (FIG 9-B) equal in height to bracket (FIG 9-A) to fully support bracket. Weld along all joint edges of gusset using welding instructions.

BOLT ON APPLICATION

1. Fasten coupler to bracket with two 5/8" diameter bolts S.A.E. grade 8 and lock nuts or nuts and lock washers.
2. Torque bolts to 200-230 ft. lbs. (dry).
3. Retorque bolts after first two hours of service, then continue to follow maintenance schedule.

OPERATION

WARNING PERSONAL INJURY

- Safe towing practice requires the proper use of safety chains used in accordance with instructions provided by the trailer manufacturer.
- Check that the ball has been completely inserted into the coupler ball socket and the ball clamp (inside the coupler) is closed around the underside of the tow ball and the handle is in the closed position.
- The loaded weight of the trailer must never exceed the maximum capacity marked on the coupler, tow ball and hitch of the trailer or vehicle.
- Check coupler, hitch and ball for damage or wear before each use. Assure all parts operate freely. Replace any component if worn or damaged.
- Failure to follow warnings and instructions could result in separation of tow vehicle and trailer which can result in death, personal injury and property damage.
- For proper tow vehicle and trailer hookup, towing performance and to prevent damage to hitch and trailer coupling, the tow vehicle and trailer are to be level with respect to flat ground after hitching up. If your trailer is not level, equipment is available to raise or lower the hitch ball.

CAUTION PRODUCT DAMAGE

- Use caution when backing or towing vehicle for hook-up.
- Do not set closed coupler on ball.
- Avoid sharp turns when towing or backing. Jack-knifing could bend coupler or create extreme stress or fracture to coupler, coupler attachment and trailer frame.

LATCHING INSTRUCTIONS

THUMB LATCH COUPLERS

PART # 80281, 81906, 81911, 81912, 81915, 81916, 82680, 82681, 82682, 83461, 83551, 83556, 84060, 84102, 84140, 86040

WARNING PERSONAL INJURY

- Always open latch handle before inserting ball.

1. With thumb, press down and back on latch (FIG 8-A). Latch will catch at rear of slot and remain open (FIG 8-B).
2. Place coupler on 2-5/16" ball of same or greater capacity than trailer GVW.
3. When ball is completely nested in ball socket, push down and forward on latch until rear of latch locks in slot FIG 9-C.

4. When ball is completely nested in ball socket, push forward on latch (FIG 3.)
For adjustable height couplers, be sure that the nib (FIG 2-A) on the latch is secured in slot (FIG 2-B.)
 5. After closing coupler on ball, extend jack to ground and lift car/trailer combination 2"-4" to insure coupler is securely attached to tow ball.
Retract jack before towing.
 6. Insert padlock or bolt through hole in latch.
- Note: These couplers are not adjustable for ball size.

MAINTENANCE

1. Lubricate ball socket and ball clamp with wheel bearing grease.
Clean and lubricate monthly.
2. Check towing hitch, ball and coupler for signs or wear before each trip. Replace coupler if damaged or worn.
3. Lubricate moving or sliding parts monthly with S.A.E. 30 weight oil.
4. Should problems or questions arise, contact your dealer, the trailer manufacturer or Atwood Service Department 574-264-2131 between the hours of 8:00 AM and 4:50 PM CST.
5. For Warranty information contact Atwood before having any work done 574-264-2131.

ATWOOD LIMITED WARRANTY

Atwood Mobile Products warrants to the retail owner and subject to the below mentioned conditions, that this product will be free of defects in material or workmanship for a period of two years from the original date of purchase. Atwood's liability hereunder is limited to the replacement of the product, repair of the product, or replacement of the product with a reconditioned product at the discretion of the manufacturer. This warranty is void if the product has been damaged by accident, unreasonable use, neglect, tampering or other causes not arising from defects in material or workmanship. This warranty extends to the original owner of the product only and is subject to the following conditions:

1. For two (2) years commencing with the date of purchase, Atwood will provide the replacement or repair of any Hardware System and Components that are found to be defective by Atwood in material or workmanship.
2. **In the event of a warranty claim, the original owner must contact the Atwood Consumer Service Department, 1120 North Main, Elkhart, IN 46514 USA. Phone: (574-264-2131).** Warranty Claim Service must be performed as approved by the Atwood Consumer Service Department. Warranty replacement hardware systems and

components or parts will be furnished freight. Prepaid labor cost to repair or replace will be limited to the amount of the original purchase price of the systems and components. The replaced warranty products or parts become the property of Atwood Mobile Products and must be returned to the Atwood Consumer Service Department freight prepaid, unless prior arrangements have been made.

3. This limited warranty is valid only when the product is applied, installed, maintained and operated in accordance with this Atwood Installation Maintenance and Operating Manual. Any deviation from these recommended specifications must be approved in writing by Atwood.
4. ANY IMPLIED WARRANTIES arising by way of State Law, including any implied warranty of merchantability and any implied warranty of fitness for a particular purpose are limited in duration to the term of this Limited Warranty. Atwood makes no further warranty of any nature beyond this Limited Warranty. No person has authority to enlarge, amend or modify this Limited Warranty.
5. Any action to enforce this warranty shall not be commenced more than one (1) year after the expiration of this warranty. 11.21.07

Box Beam

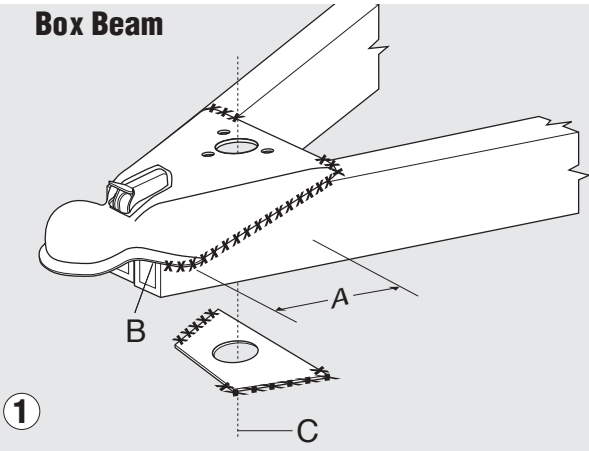

I Beam

